

Wobbler Idler

Summary

Designed to solve common belt training problems –

The Wobbler idler is a return training idler designed to train your conveyor belt. A steel roll, centered on a 60mm ball bearing, pivots when the conveyor belt moves off center and guides the belt back to allow for a more efficient operating conveyor. The Wobbler idler is available in belt widths from 18" to 60".

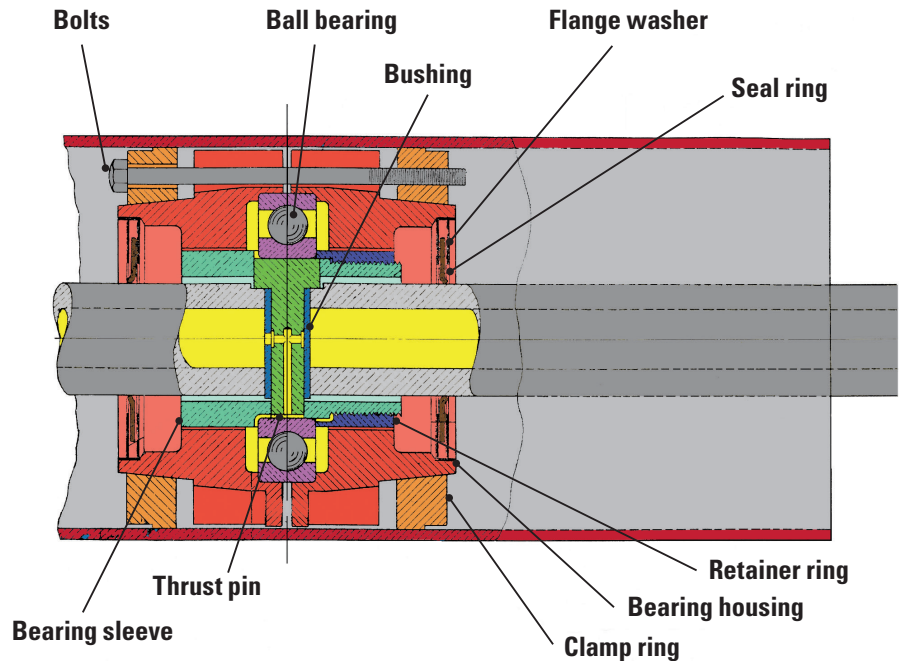

Optional urethane available

For sticky material or adverse weather conditions, request the Wobbler return trainer with a 1/4" urethane cover that is designed to reduce material buildup on the surface of the idler.

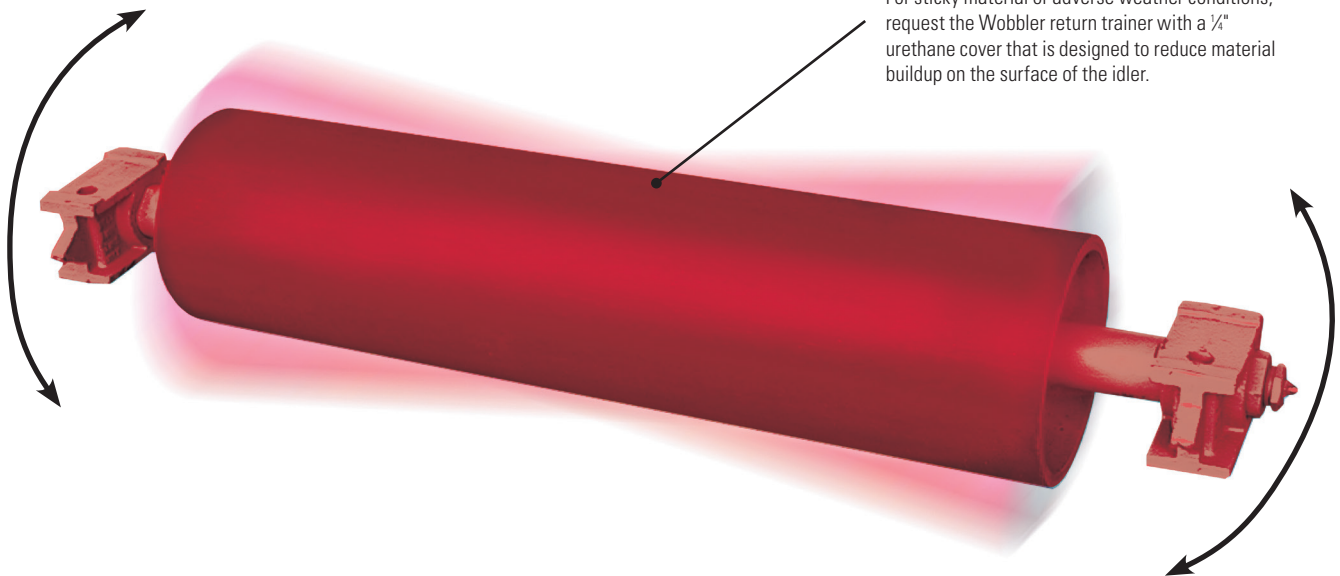

Benefits

The Wobbler idler also solves another common problem. Most trainers have complex frames which accumulate so much material that the roll jams, causing possible de-training and damage to the belt. The Wobbler return training idler is held in place by two simple brackets with no framework to collect material. Lubrication can be accomplished from either side.

Description

The Wobbler idler is a return training idler made up of a tubular roll mounted on an anti-friction bearing in the center of the tube. The idler is pivoted on an inclined, fixed swivel pin. If the weight of the belt falls more on one side than the other, the heavy side rocks downward and forward, skewing the roller and guiding the belt to its central position.

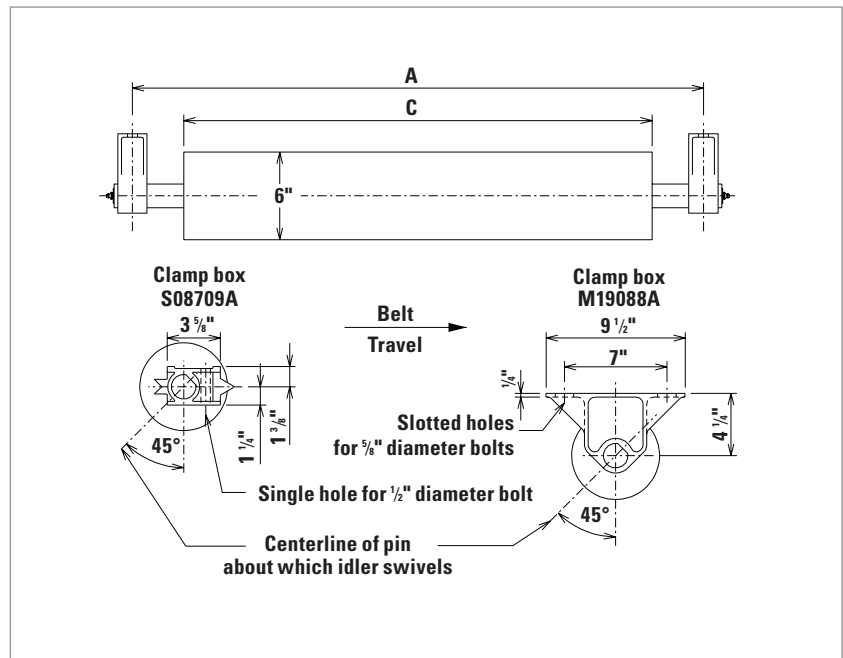

D6-RAW-BWB			
Belt width	A	C	WT
18	27	20	59
24	33	26	67
30	39	32	75
36	45	38	83
42	51	44	91
48	57	50	99
54	63	56	107
60	69	62	115

S08709A clamp box will be supplied if not specified.

Available in 6" diameter rolls only.

Bolts, nuts, and washers for mounting are not included. Weights are in pounds, and lengths are in inches. Weights and dimensions are subject to change or correction without notice. Use certified prints for construction purposes.



Phone: +1 205 487 6492
www.cgmh.com

Products pictured, described, or listed in this publication are illustrative only and are not warranties of any kind. The only warranties that apply to sales of products and services are standard written warranties, which will be furnished upon request. Product designs and/or specifications may be changed or corrected at any time without notice. Application and use of these products must be in accordance with applicable codes and regulations and must be arranged and/or provided with covers or other guards where necessary to assure safety of personnel.

All weights are in pounds, and all lengths are in inches. Weights and dimensions are subject to change or correction without notice. Use certified prints for construction purposes.

Continental and other trademarks used herein are the property of Continental Global Material Handling LLC.

©2024 Continental Global Material Handling LLC. All rights reserved.